

# Comlinear® CLC1006

## Single, 500MHz Voltage Feedback Amplifier

### FEATURES

- 500MHz -3dB bandwidth at G=2
- 1,400V/ $\mu$ s slew rate
- 0.06%/0.06° differential gain/phase error
- 5.5mA supply current
- 6nV/ $\sqrt{\text{Hz}}$  input voltage noise
- 100mA output current
- Fully specified at 5V and  $\pm$ 5V supplies
- CLC1006: Pb-free SOT23-5

### APPLICATIONS

- Video line drivers
- Imaging applications
- Professional cameras
- Differential line receivers
- Photodiode preamps
- Radar or communication receivers

### General Description

The *Comlinear* CLC1006 is a high-performance, voltage feedback amplifier that offers bandwidth and slew rate usually found in current feedback amplifiers. The CLC1006 provides 500MHz bandwidth and 1,400V/ $\mu$ s slew rate exceeding the requirements of standard-definition television and other multi-media applications. The *Comlinear* CLC1006 high-performance amplifier also provides ample output current to drive multiple video loads.

The *Comlinear* CLC1006 is designed to operate from  $\pm$ 5V or +5V supplies. It consumes only 5.5mA of supply current. The combination of high-speed, excellent video performance, and 10ns settling time make the CLC1006 well suited for use in many general purpose, high-speed applications including standard definition video and imaging applications.

### Typical Application - Driving Dual Video Loads

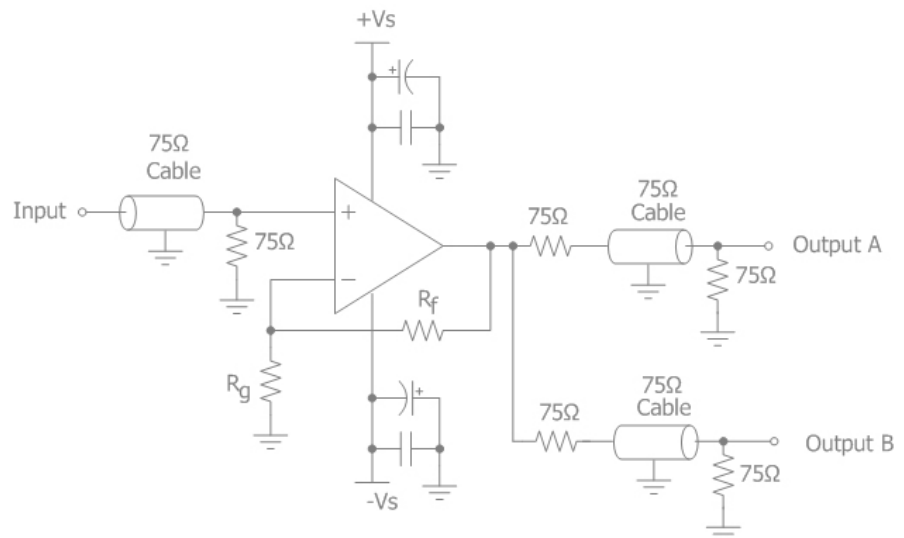

### Ordering Information

Part Number	Package	Pb-Free	Operating Temperature Range	Packaging Method
CLC1006IST5X	SOT23-5	Yes	-40°C to +85°C	Reel

Moisture sensitivity level for all parts is MSL-1.



## CLC1006 Pin Configuration

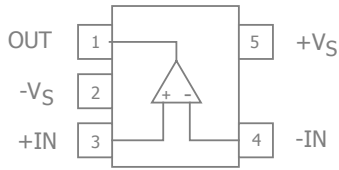

## CLC1006 Pin Assignments

Pin No.	Pin Name	Description
1	OUT	Output
2	$-V_S$	Negative supply
3	+IN	Positive input
4	-IN	Negative input
5	$+V_S$	Positive supply



## Absolute Maximum Ratings

The safety of the device is not guaranteed when it is operated above the "Absolute Maximum Ratings". The device should not be operated at these "absolute" limits. Adhere to the "Recommended Operating Conditions" for proper device function. The information contained in the Electrical Characteristics tables and Typical Performance plots reflect the operating conditions noted on the tables and plots.

Parameter	Min	Max	Unit
Supply Voltage	0	14	V
Input Voltage Range	$-V_S - 0.5V$	$+V_S + 0.5V$	V

## Reliability Information

Parameter	Min	Typ	Max	Unit
Junction Temperature			150	°C
Storage Temperature Range	-65		150	°C
Lead Temperature (Soldering, 10s)			260	°C
Package Thermal Resistance				
5-Lead SOT23		221		°C/W

Notes:

Package thermal resistance ( $\theta_{JA}$ ), JEDEC standard, multi-layer test boards, still air.

## ESD Protection

Product	SOT23-5
Human Body Model (HBM)	2kV
Charged Device Model (CDM)	1kV

## Recommended Operating Conditions

Parameter	Min	Typ	Max	Unit
Operating Temperature Range	-40		+85	°C
Supply Voltage Range	4.5		12	V



## Electrical Characteristics at +5V

$T_A = 25^\circ\text{C}$ ,  $V_S = +5\text{V}$ ,  $R_f = 150\Omega$ ,  $R_L = 150\Omega$  to  $V_S/2$ ,  $G = 2$ ; unless otherwise noted.

Symbol	Parameter	Conditions	Min	Typ	Max	Units
Frequency Domain Response						
UGBW	-3dB Bandwidth	$G = +1$ , $V_{OUT} = 0.2V_{pp}$		TBD		MHz
BW <sub>SS</sub>	-3dB Bandwidth	$G = +2$ , $V_{OUT} = 0.2V_{pp}$		400		MHz
BW <sub>LS</sub>	Large Signal Bandwidth	$G = +2$ , $V_{OUT} = 1V_{pp}$		200		MHz
BW <sub>0.1dBSS</sub>	0.1dB Gain Flatness	$G = +2$ , $V_{OUT} = 0.2V_{pp}$		10		MHz
BW <sub>0.1dBLS</sub>	0.1dB Gain Flatness	$G = +2$ , $V_{OUT} = 1V_{pp}$		TBD		MHz
Time Domain Response						
$t_R$ , $t_F$	Rise and Fall Time	$V_{OUT} = 1\text{V}$ step; (10% to 90%)		2.2		ns
$t_S$	Settling Time to 0.1%	$V_{OUT} = 1\text{V}$ step		10		ns
OS	Overshoot	$V_{OUT} = 0.2\text{V}$ step		1		%
SR	Slew Rate	1V step		800		V/ $\mu\text{s}$
Distortion/Noise Response						
HD2	2nd Harmonic Distortion	$1V_{pp}$ , 5MHz		-60		dBc
HD3	3rd Harmonic Distortion	$1V_{pp}$ , 5MHz		-67		dBc
THD	Total Harmonic Distortion	$1V_{pp}$ , 5MHz		-59		dB
IP3	Third-Order Intercept	$0.5V_{pp}$ , 10MHz		35		dBm
SFDR	Spurious-Free Dynamic Range	$1V_{pp}$ , 5MHz		60		dBc
D <sub>G</sub>	Differential Gain	NTSC (3.58MHz), DC-coupled, $R_L = 150\Omega$		0.07		%
D <sub>P</sub>	Differential Phase	NTSC (3.58MHz), DC-coupled, $R_L = 150\Omega$		0.06		°
$e_n$	Input Voltage Noise	> 1MHz		6		nV/ $\sqrt{\text{Hz}}$
$i_n$	Input Current Noise	> 1MHz		3		pA/ $\sqrt{\text{Hz}}$
DC Performance						
$V_{IO}$	Input Offset Voltage			0		mV
$dV_{IO}$	Average Drift			6.0		$\mu\text{V}/^\circ\text{C}$
$I_{bn}$	Input Bias Current			$\pm 3.2$		$\mu\text{A}$
$dI_b$	Average Drift			40		nA/ $^\circ\text{C}$
PSRR	Power Supply Rejection Ratio	DC		60		dB
$A_{OL}$	Open-Loop Gain			TBD		dB
$I_S$	Supply Current			5.2		mA
Input Characteristics						
$R_{IN}$	Input Resistance	Non-inverting		4.5		M $\Omega$
$C_{IN}$	Input Capacitance			1.0		pF
CMIR	Common Mode Input Range			$\pm 1.5$		V
CMRR	Common Mode Rejection Ratio	DC		50		dB
Output Characteristics						
$R_O$	Output Resistance	Closed Loop, DC		0.1		$\Omega$
$V_{OUT}$	Output Voltage Swing	$R_L = 150\Omega$		$\pm 1.5$		V
$I_{OUT}$	Output Current			$\pm 100$		mA
$I_{SC}$	Short-Circuit Output Current	$V_{OUT} = V_S / 2$		TBD		mA

### Notes:

1.



## Electrical Characteristics at $\pm 5V$

$T_A = 25^\circ C$ ,  $V_S = \pm 5V$ ,  $R_f = 150\Omega$ ,  $R_L = 150\Omega$ ,  $G = 2$ ; unless otherwise noted.

Symbol	Parameter	Conditions	Min	Typ	Max	Units
Frequency Domain Response						
UGBW	-3dB Bandwidth	$G = +1$ , $V_{OUT} = 0.2V_{pp}$		TBD		MHz
BW <sub>SS</sub>	-3dB Bandwidth	$G = +2$ , $V_{OUT} = 0.2V_{pp}$		500		MHz
BW <sub>LS</sub>	Large Signal Bandwidth	$G = +2$ , $V_{OUT} = 2V_{pp}$		300		MHz
BW <sub>0.1dBSS</sub>	0.1dB Gain Flatness	$G = +2$ , $V_{OUT} = 0.2V_{pp}$		15		MHz
BW <sub>0.1dBLS</sub>	0.1dB Gain Flatness	$G = +2$ , $V_{OUT} = 2V_{pp}$		TBD		MHz
Time Domain Response						
$t_R$ , $t_F$	Rise and Fall Time	$V_{OUT} = 2V$ step; (10% to 90%)		2.4		ns
$t_S$	Settling Time to 0.1%	$V_{OUT} = 2V$ step		10		ns
OS	Overshoot	$V_{OUT} = 0.2V$ step		1		%
SR	Slew Rate	2V step		1400		V/ $\mu$ s
Distortion/Noise Response						
HD2	2nd Harmonic Distortion	$2V_{pp}$ , 5MHz		-68		dBc
HD3	3rd Harmonic Distortion	$2V_{pp}$ , 5MHz		-63		dBc
THD	Total Harmonic Distortion	$2V_{pp}$ , 5MHz		-62		dB
IP3	Third-Order Intercept	$0.5V_{pp}$ , 10MHz		40		dBm
SFDR	Spurious-Free Dynamic Range	$2V_{pp}$ , 5MHz		63		dBc
D <sub>G</sub>	Differential Gain	NTSC (3.58MHz), DC-coupled, $R_L = 150\Omega$		0.06		%
D <sub>P</sub>	Differential Phase	NTSC (3.58MHz), DC-coupled, $R_L = 150\Omega$		0.06		°
$e_n$	Input Voltage Noise	> 1MHz		6		nV/ $\sqrt{Hz}$
$i_{ni}$	Input Current Noise	> 1MHz		3		pA/ $\sqrt{Hz}$
DC Performance						
$V_{IO}$	Input Offset Voltage <sup>(1)</sup>		-10	0	10	mV
$dV_{IO}$	Average Drift			6.0		$\mu$ V/ $^\circ C$
$I_b$	Input Bias Current <sup>(1)</sup>		-20	$\pm 3.2$	20	$\mu$ A
$dI_b$	Average Drift			40		nA/ $^\circ C$
PSRR	Power Supply Rejection Ratio <sup>(1)</sup>	DC	40	60		dB
$A_{OL}$	Open-Loop Gain			TBD		dB
$I_S$	Supply Current <sup>(1)</sup>			5.5	10	mA
Input Characteristics						
$R_{IN}$	Input Resistance	Non-inverting		4.5		M $\Omega$
$C_{IN}$	Input Capacitance			1.0		pF
CMIR	Common Mode Input Range			$\pm 4.0$		V
CMRR	Common Mode Rejection Ratio <sup>(1)</sup>	DC	40	50		dB
Output Characteristics						
$R_O$	Output Resistance	Closed Loop, DC		0.1		$\Omega$
$V_{OUT}$	Output Voltage Swing	$R_L = 150\Omega$ <sup>(1)</sup>	$\pm 3.0$	$\pm 4.0$		V
$I_{OUT}$	Output Current			$\pm 100$		mA
$I_{SC}$	Short-Circuit Output Current	$V_{OUT} = V_S / 2$		TBD		mA

### Notes:

- 100% tested at 25°C

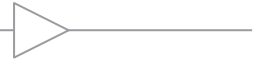

## Mechanical Dimensions

### SOT23-5 Package

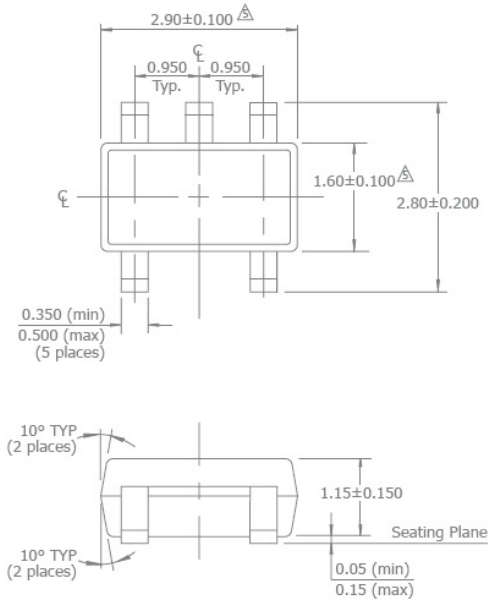

**NOTES:**

1. Dimensions and tolerances are as per ANSI Y14.5M-1982.
  2. Package surface to be matte finish VDI 11~13.
  3. Die is facing up for mold. Die is facing down for trim/form, ie. reverse trim/form.
  4. The footlength measuring is based on the gauge plane method.
- △ Dimension are exclusive of mold flash and gate burr.  
 △ Dimension are exclusive of solder plating.

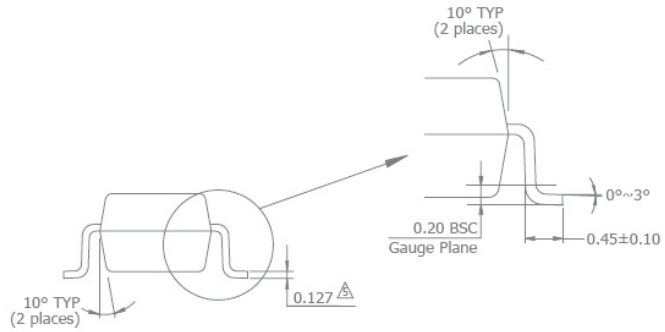

For additional information regarding our products, please visit CADEKA at: [cadeka.com](http://cadeka.com)

**CADEKA Headquarters** Loveland, Colorado  
 T: 970.663.5452  
 T: 877.663.5415 (toll free)

CADEKA, the CADEKA logo design, and Comlinear and the Comlinear logo design, are trademarks or registered trademarks of CADEKA Microcircuits LLC. All other brand and product names may be trademarks of their respective companies.

CADEKA reserves the right to make changes to any products and services herein at any time without notice. CADEKA does not assume any responsibility or liability arising out of the application or use of any product or service described herein, except as expressly agreed to in writing by CADEKA; nor does the purchase, lease, or use of a product or service from CADEKA convey a license under any patent rights, copyrights, trademark rights, or any other of the intellectual property rights of CADEKA or of third parties.

Copyright ©2008 by CADEKA Microcircuits LLC. All rights reserved.

